



SIT Group

# 8 2 0 N O V A

---

MULTIFUNCTIONAL GAS CONTROL



**THERMOELECTRIC FLAME SUPERVISION DEVICE**

**SERVO-CONTROLLED PRESSURE REGULATOR**

**AUTOMATIC SHUT-OFF VALVE**



## MULTIFUNCTIONAL GAS SINGLE-CONTROL

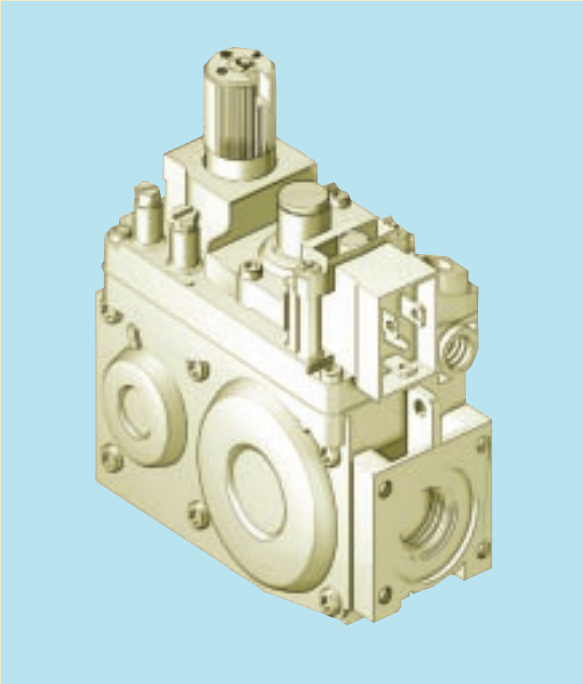

**Multifunctional control with thermoelectric flame supervision device, single-control knob (Off, Pilot, On), restart interlock, servo-controlled pressure regulator, on/off electric solenoid.**

**A step opening ignition device can be fitted on request.**

*The 820 NOVA is suitable for use with boilers, catering equipment, hot air generators, radiators and other heating appliances.*

### MAIN FEATURES

- Control knob with Off, Pilot and On positions.
  - Thermoelectric flame supervision device with re-start interlock.
  - Near silent shut-off valve.
  - Servo-controlled pressure regulator.
  - Step opening ignition device (optional).
  - Main gas flow control (optional).
  - Pilot outlet with gas flow adjustment screw.
  - Inlet and pilot filters.
  - Inlet and outlet pressure test points.
  - Threaded gas inlet and outlet with provision for flange connection.
  - Connection for combustion chamber pressure regulator compensation.
-

## DESCRIPTION

- |   |  |
|---|--|
| 1 Control knob                              | 9 Actuation valve  |
| 2 Pressure regulator cap screw              | 10 Pilot outlet  |
| 3 Pilot gas rate adjuster                   | 11 Main gas outlet   |
| 4 Thermocouple connection                   | 12 Holes (M5) for mounting flange  |
| 5 Alternative thermocouple connection       | 13 Supplementary fixing points for valve                                   |
| 6 Provision for accessories support bracket | 14 Connection point for combustion chamber pressure regulator compensation |
| 7 Inlet pressure test point                 |  |
| 8 Outlet pressure test point                |  |

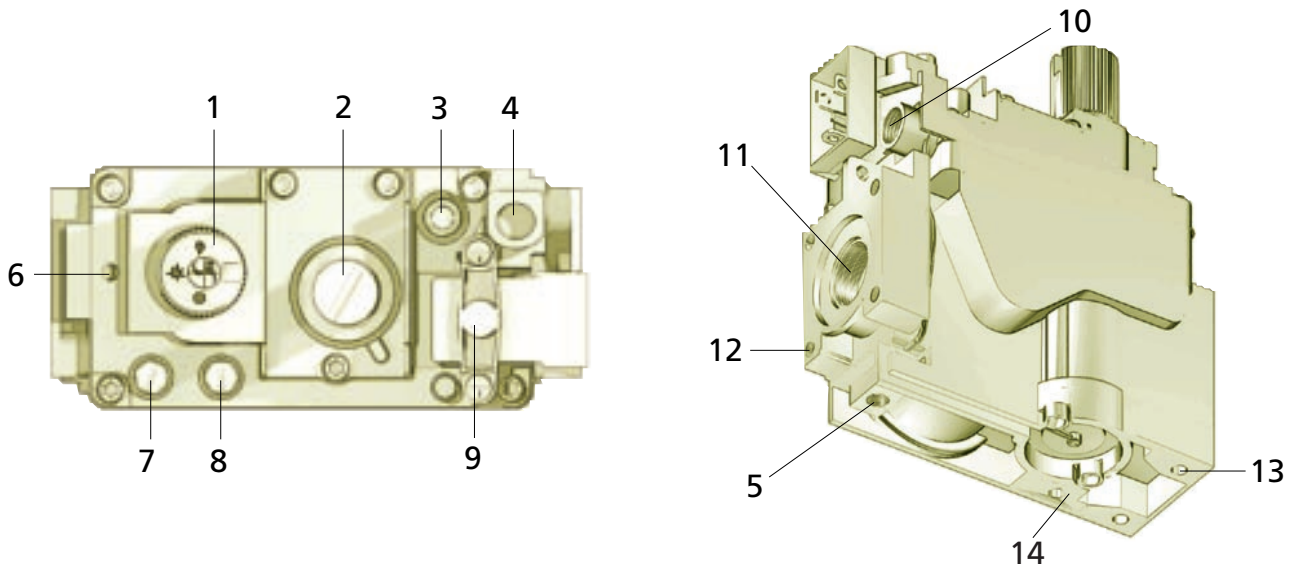

## TECHNICAL DATA

- |  |                                   |
|--|-----------------------------------|
| • Gas connections:                       | Rp 1/2 ISO 7                      |
| • Installation positions:                | any                               |
| • Gas families:                          | I, II and III                     |
| • Maximum gas inlet pressure:            | 60 mbar                           |
| • Maximum outlet pressure setting range: | 3...30 mbar (optional 20...50)    |
| • Working temperature range:             | 0...70 °C (optional -20... +60°C) |
| • Pressure regulator:                    | Class B                           |
| • Automatic shut-off valve:              | Class D (Class C on request)      |

### ELECTRICAL DATA

Supply Voltage (AC)	Consumption (mA)
240 V 50 Hz	25
220 V 50 Hz	20
220 V 60 Hz	25
24 V 50 Hz	210
24 V 60 Hz	220

Electrical protection rating *IP54 using 160-type connectors with screw and gasket - code 0.960.104*

Data refer to EN 126

## DIMENSIONS

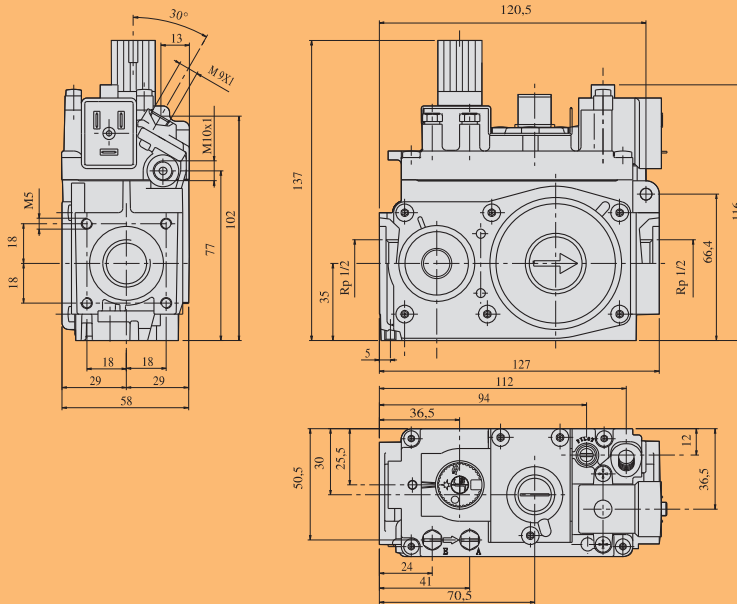

## GAS FLOW AS A FUNCTION OF PRESSURE LOSS

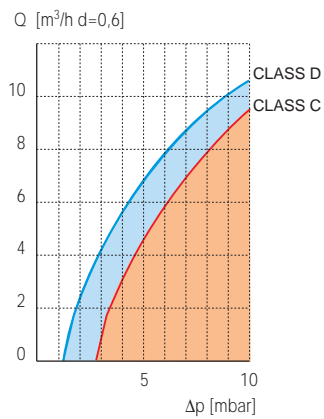

CLASS D		
I Family (d = 0.45)	Q = 7.5 m <sup>3</sup> /h	Δp = 5 mbar
II Family (d = 0.6)	Q = 6.5 m <sup>3</sup> /h	Δp = 5 mbar
III Family (d = 1.7)	Q = 8.1 kg/h	Δp = 5 mbar

CLASS C		
I Family (d = 0.45)	Q = 5.3 m <sup>3</sup> /h	Δp = 5 mbar
II Family (d = 0.6)	Q = 4.6 m <sup>3</sup> /h	Δp = 5 mbar
III Family (d = 1.7)	Q = 5.8 kg/h	Δp = 5 mbar

## ACTUATION

### Pilot flame ignition

Press the control knob and rotate to Pilot ✨ .

Press the knob and ignite the pilot flame, keeping the knob fully depressed for a few seconds (fig. 1).

Release the knob and check the pilot flame stays on, otherwise repeat the ignition procedure.



fig. 1

### Main burner ignition

Slightly depress the control knob and rotate to On 🔥 (fig. 2).

When the automatic valve is powered, the gas flow to the main burner is opened.

Valves with a step opening ignition device reach the maximum rate of flow after approx. 10 seconds.



fig. 2

### Pilot position

To keep the main burner off and the pilot flame on, slightly depress the control knob and rotate to Pilot ✨ .



fig. 3

### Shut-down

Slightly depress the control knob and rotate to Off ● (fig. 3).

**CAUTION:** The re-start interlock device prevents the appliance from re-igniting until the flame supervision device has interrupted the gas flow. After this stage (i.e. when the magnet unit has closed) it is possible to re-ignite the appliance.

## GAS FLOW SET TO EN 88

$$Q = [m^3/h \text{ d}=0.6]$$

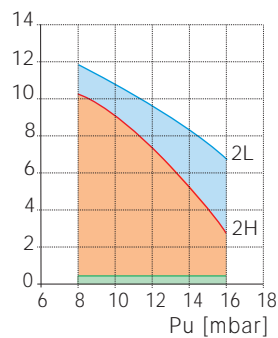

### CLASS C

Type of gas	Inlet pressure range		
	Nominal	Max.	Min.
2H	20	25	17
2L	25	30	20

Outlet pressure tolerance +10%...-15%

$$Q = [m^3/h \text{ d}=0.6]$$

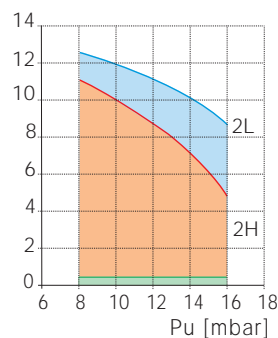

### CLASS D

Type of gas	Inlet pressure range		
	Nominal	Max.	Min.
2H	20	25	17
2L	25	30	20

Outlet pressure tolerance +10%...-15%

## INSTALLATION

### **Main gas connection**

The connection must be made using gas pipes with Rp 1/2 ISO 7. Torque: 25 Nm.  
If optional flanges are used, first screw the pipes onto the flanges and then the flanges onto the valve. Recommended torque for flange fixing screws: 3 Nm.

### **Connection to the pilot burner**

Ø 4 mm, Ø 6 mm or Ø 1/4 pipes can be used. Use appropriately sized nut and olive. Tighten to 7 Nm torque.

### **Connection to the combustion chamber**

The "air" section of the pressure regulator may be connected to the combustion chamber if the latter is under pressure.

Use the SIT fittings provided. Torque: 1 Nm

### **Electrical connections**

The use of special connectors is recommended for the mains powered versions. In order to ensure that the valve is connected to the appliance's earth circuit, always use the power connector with the earth terminal, fixing it with the appropriate screw.

The 24 VAC versions must be powered by an isolating transformer (at a very low safety voltage as per EN 60742). Use AMP 6.3x0.8 mm DIN 46244 terminals for the connection. Make the connections according to the specific standards for the appliance.

All relevant safety devices (e.g. the overheat thermostat) must cut off the power supply to the magnet unit.

**CAUTION:** When all the connections have been completed, check the gas seals and wiring insulation.

WIRING DIAGRAMS

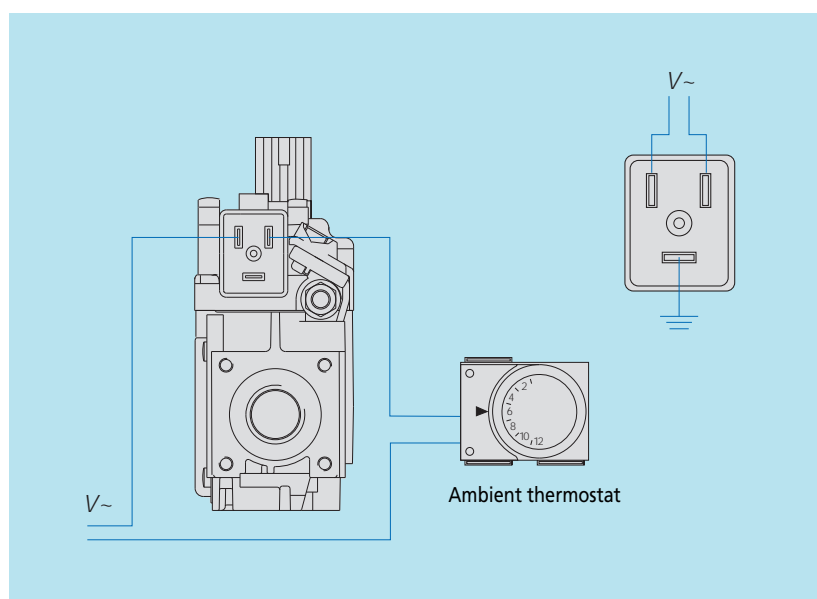

## SETTINGS AND ADJUSTMENTS

### **Checking the inlet and outlet pressure**

Loosen the test-point screws provided to check inlet and outlet pressure.

Tighten the screws to the recommended torque of 2.5 Nm.

### **Adjusting the outlet pressure**

Remove the plug (A), turn the screw (B) clockwise to increase outlet pressure and anticlockwise to reduce it. After setting, ensure plug (A) is properly secured.

### **Overriding the pressure regulator**

For conversion to operation on third family gases replace the plug (A), the adjustment screw (B) and the spring (C) with the accessory (D) - code 0.907.037. Torque: 1Nm

### **Adjusting the gas flow to the pilot burner**

Turn the relevant screw clockwise to decrease the gas flow and anticlockwise to increase it.

### **Overriding the pilot flow adjustment function**

Fully tighten the adjustment screw and then unscrew two complete turns.

### **Changing the gas family or group**

Check that the appliance is suitable for operation with the gas family or group in question. Following the instructions given above, adjust the outlet pressure to the values detailed in the manufacturer's instructions for the appliance.

If necessary, override the pressure regulator and gas flow adjustment to the pilot burner.

### **IMPORTANT:**

Check the gas seals and the efficiency of the appliance, then seal the adjustment screws.

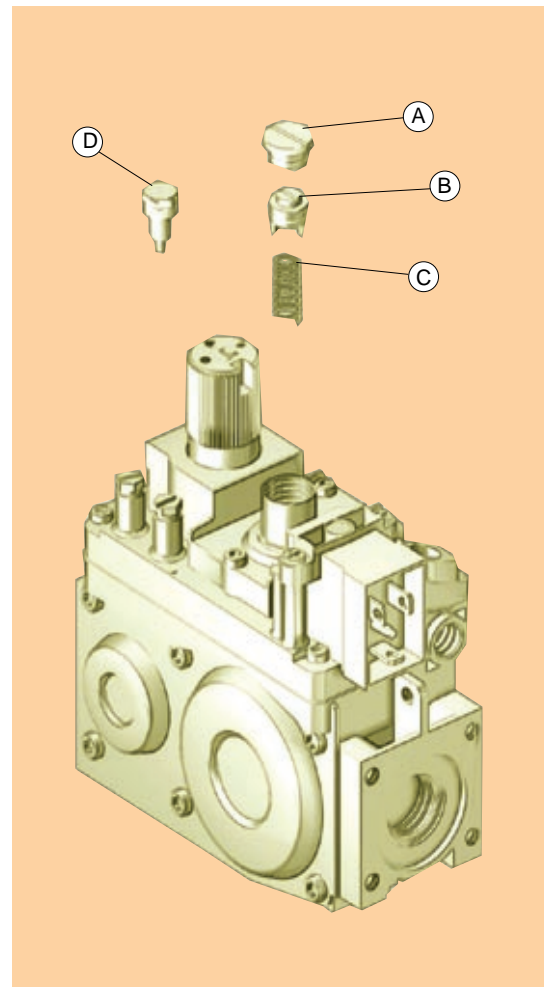

Please ensure you follow all the guidelines detailed in the installation and operation manual (code n° 9.956.820.) when installing, adjusting or operating the equipment in your possession.

820 NOVA



**Multifunctional control  
for electrically-powered  
gas appliances**

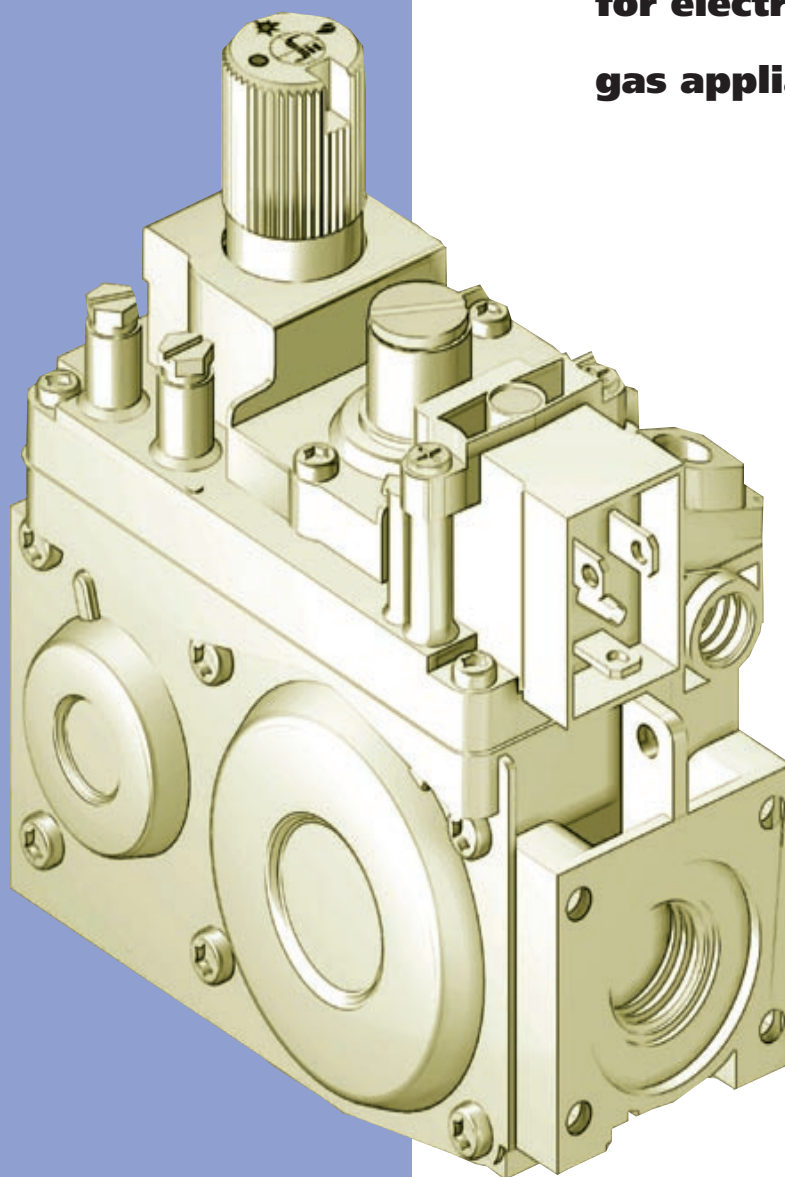

SIT La Precisa  
Viale dell'Industria 31/33 35129 PADOVA - ITALY  
Tel. 049/8293111 - Fax 049/8070093 - Telex 430130 SITEC I

